

Digital Deployment Update

Presented for PBS Technology Conference,
Michael T. Hayashi, Time Warner Cable,
April 20, 2001



Agenda

- Deployment Statistics
- Cable System Architecture
- Technology Initiatives

Deployment Statistics

- 20+ Million Homes Passed, 40 Operating Divisions
- 90% Upgraded
- ALL Digital TV Ready
 - Pegasus (90%)
 - Motorola (10%)
 - 2.5 million "boxes" per year, 50% digital subs by EOY 2003
- DOCSIS (High Speed Cable Modem) Ready - 90%
 - 15% cable modem subs by EOY 2003

Cable System Architecture

- HFC
- Spectrum Planning

Conventional Coaxial Tree & Branch Architecture

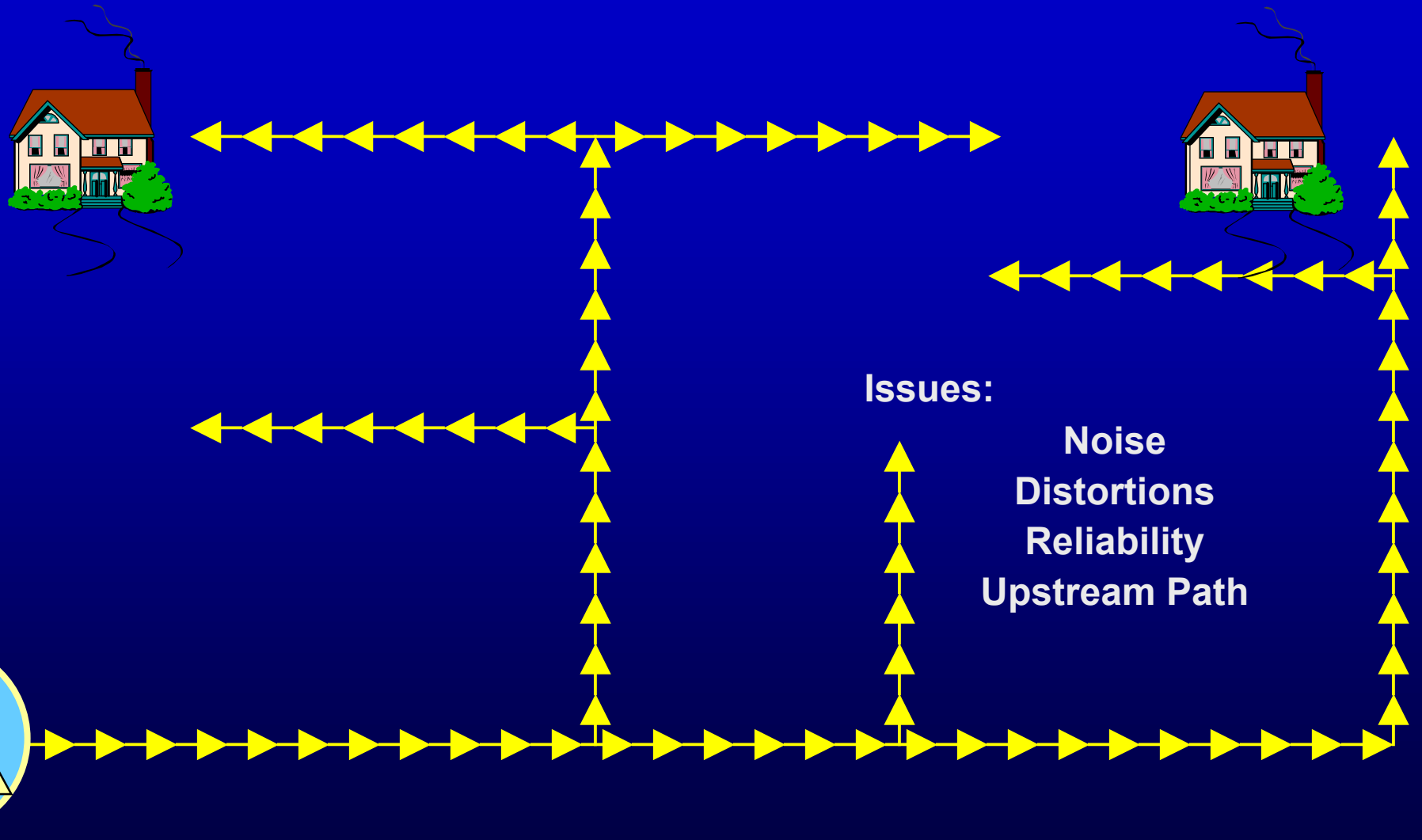

Issues:
Noise
Distortions
Reliability
Upstream Path

Typical Hybrid Fiber-Coaxial (HFC) Architecture

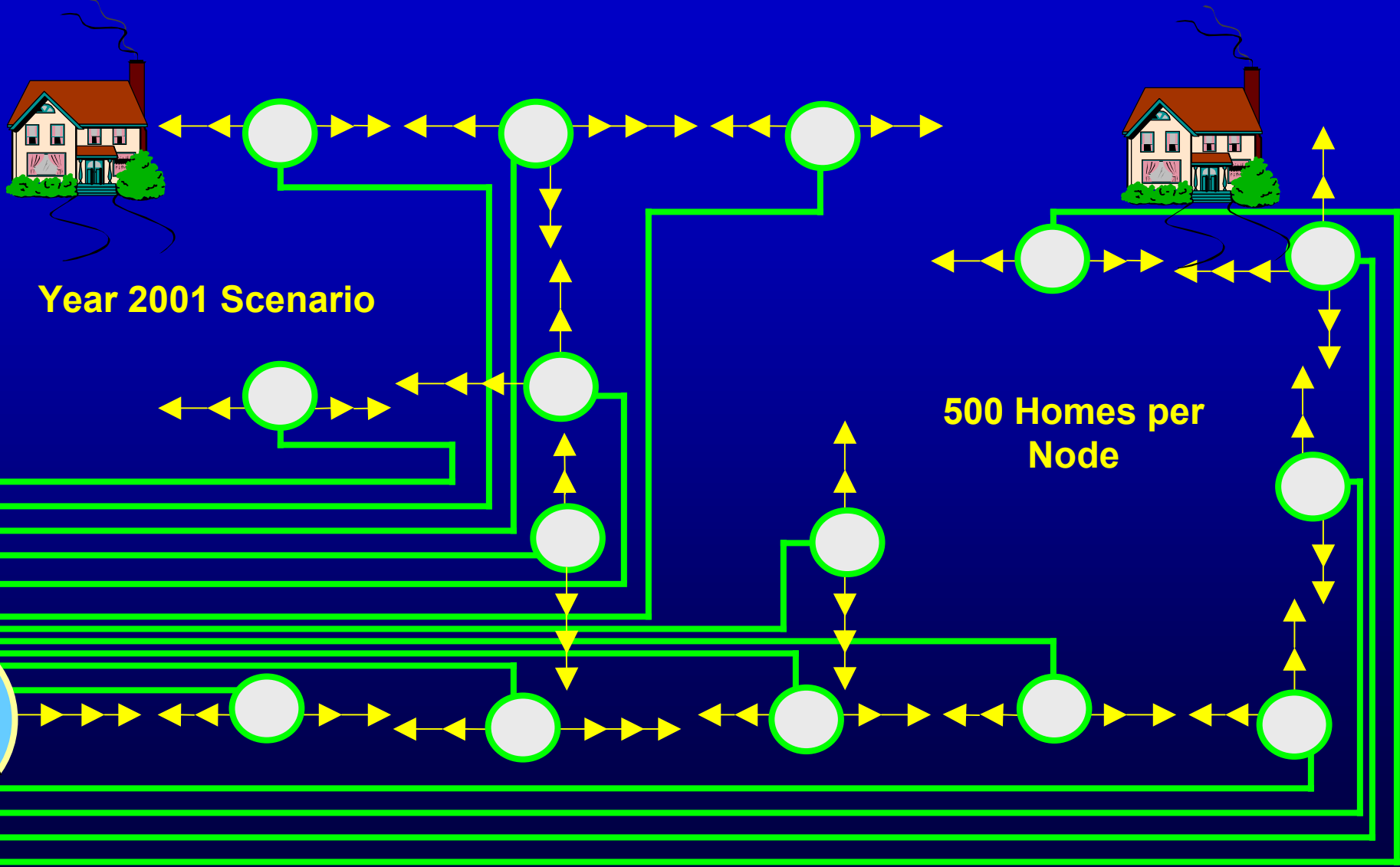

Spectrum Allocation - 750 MHz HFC System - 2001

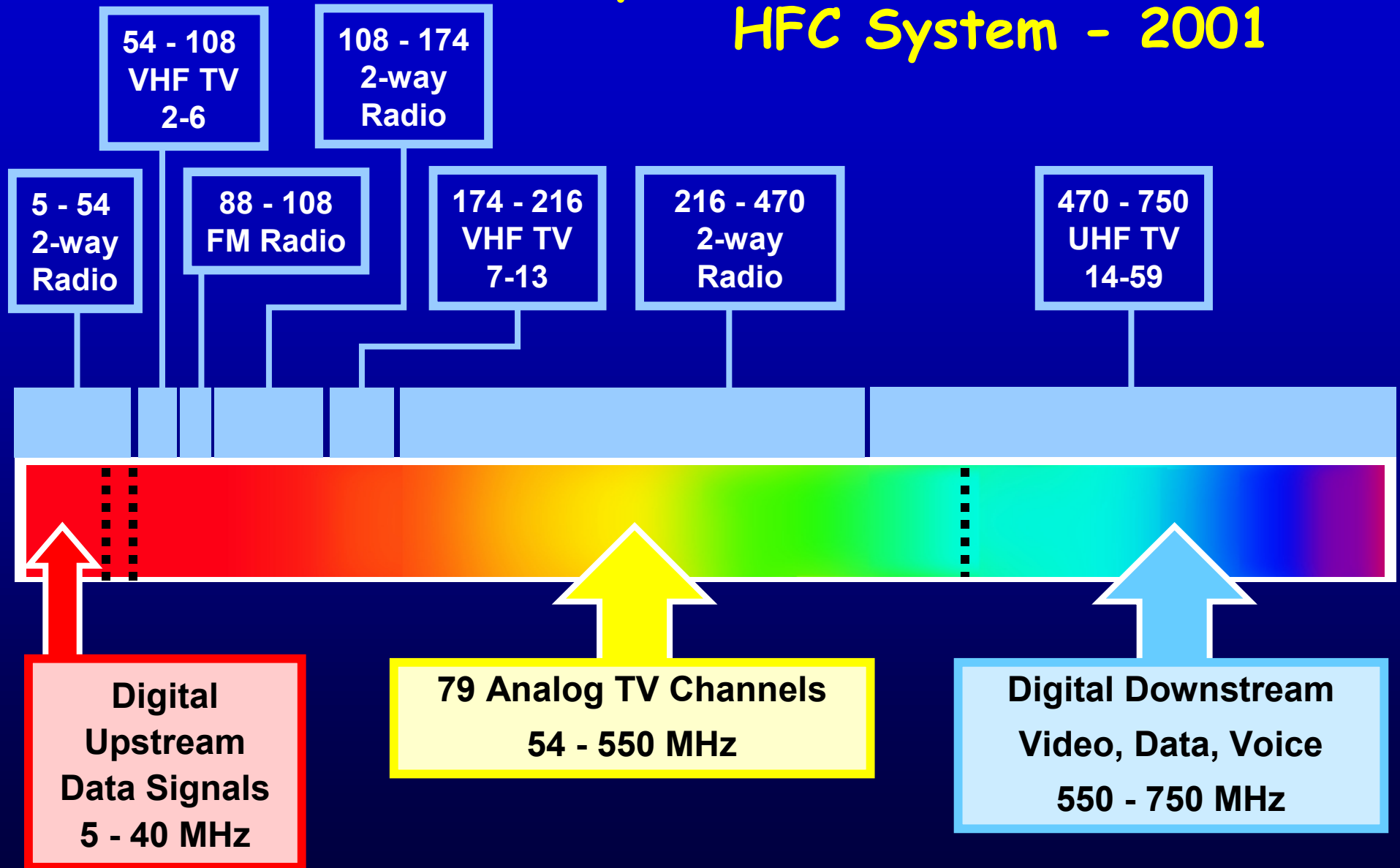

Coaxial Spectrum Allocation HFC System - 2001

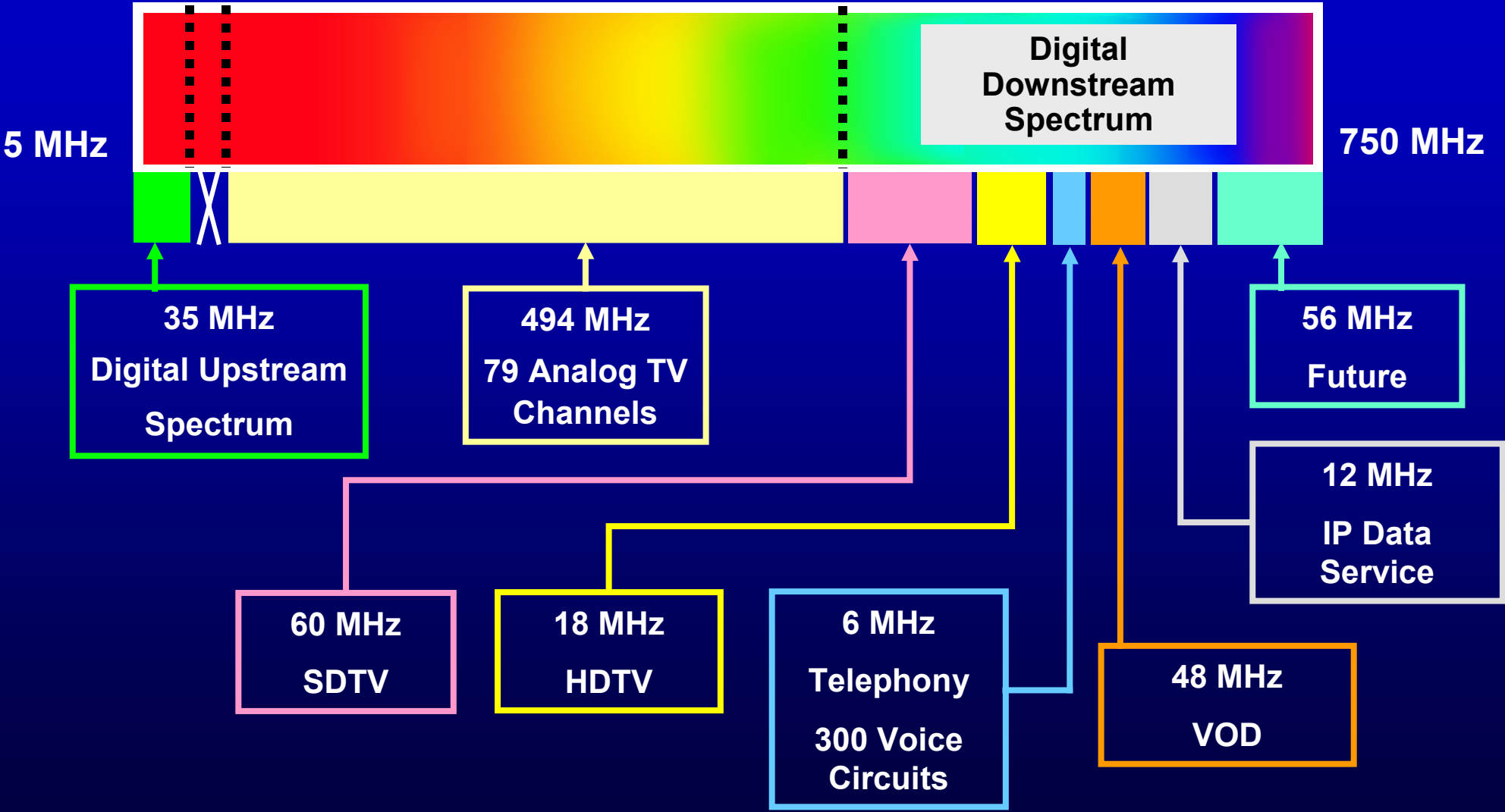

Digital Spectrum - 2001 (One Scenario)

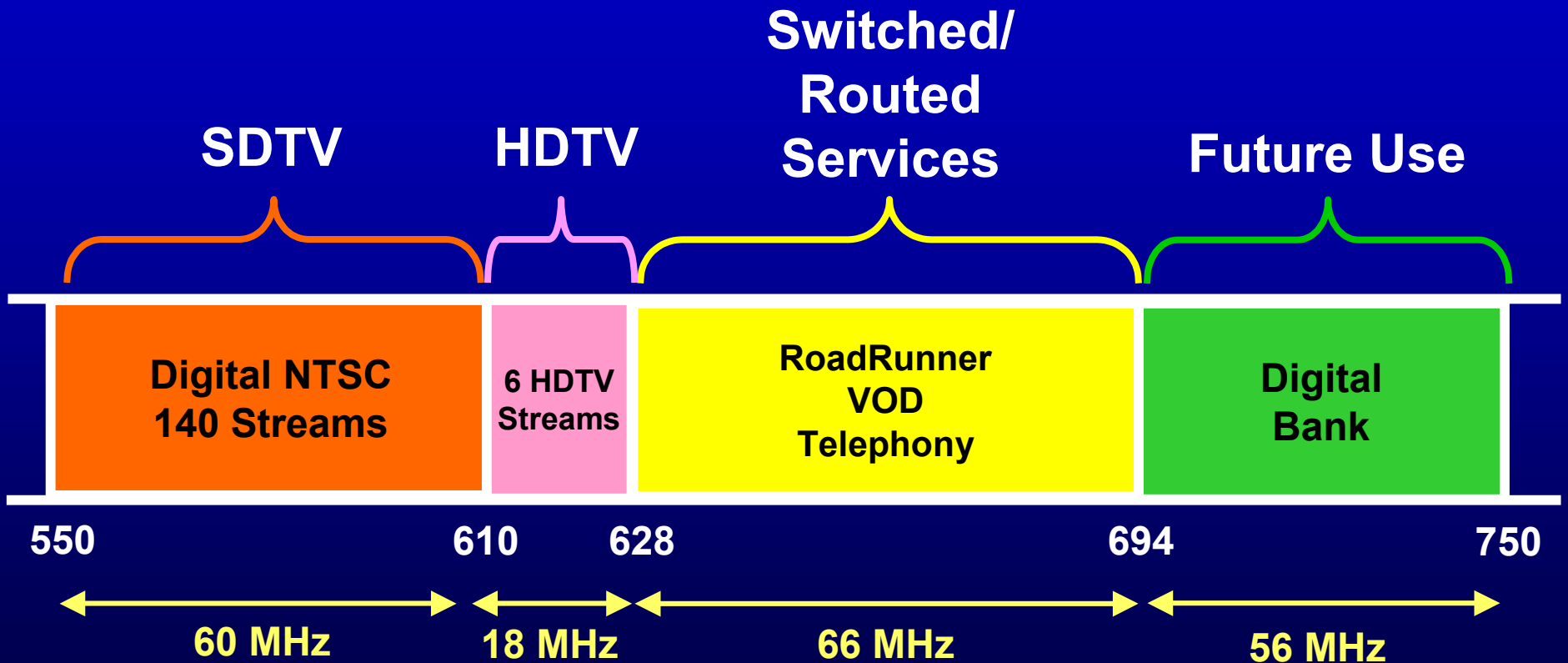

2001 Scenario

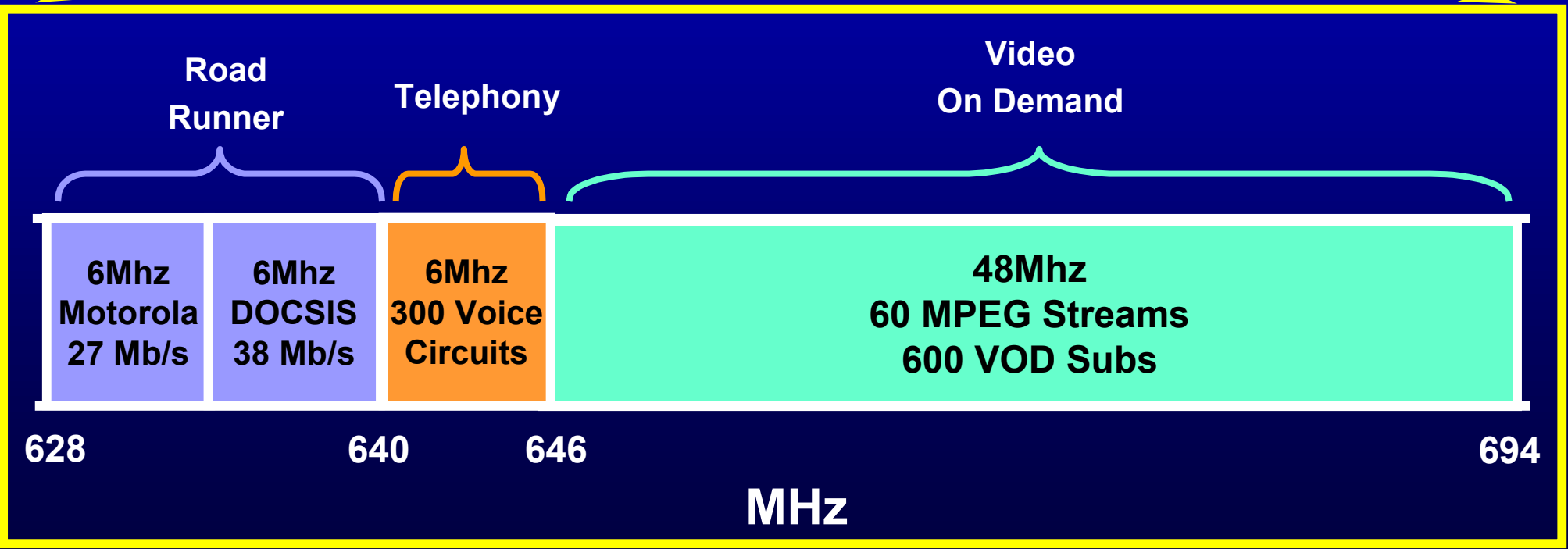
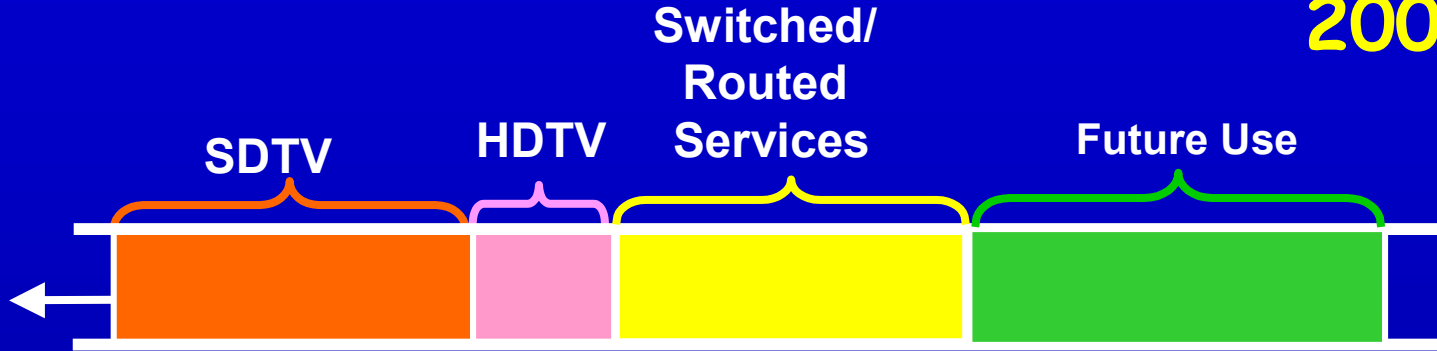

Spectrum Allocation - 750 MHz HFC System - 2005

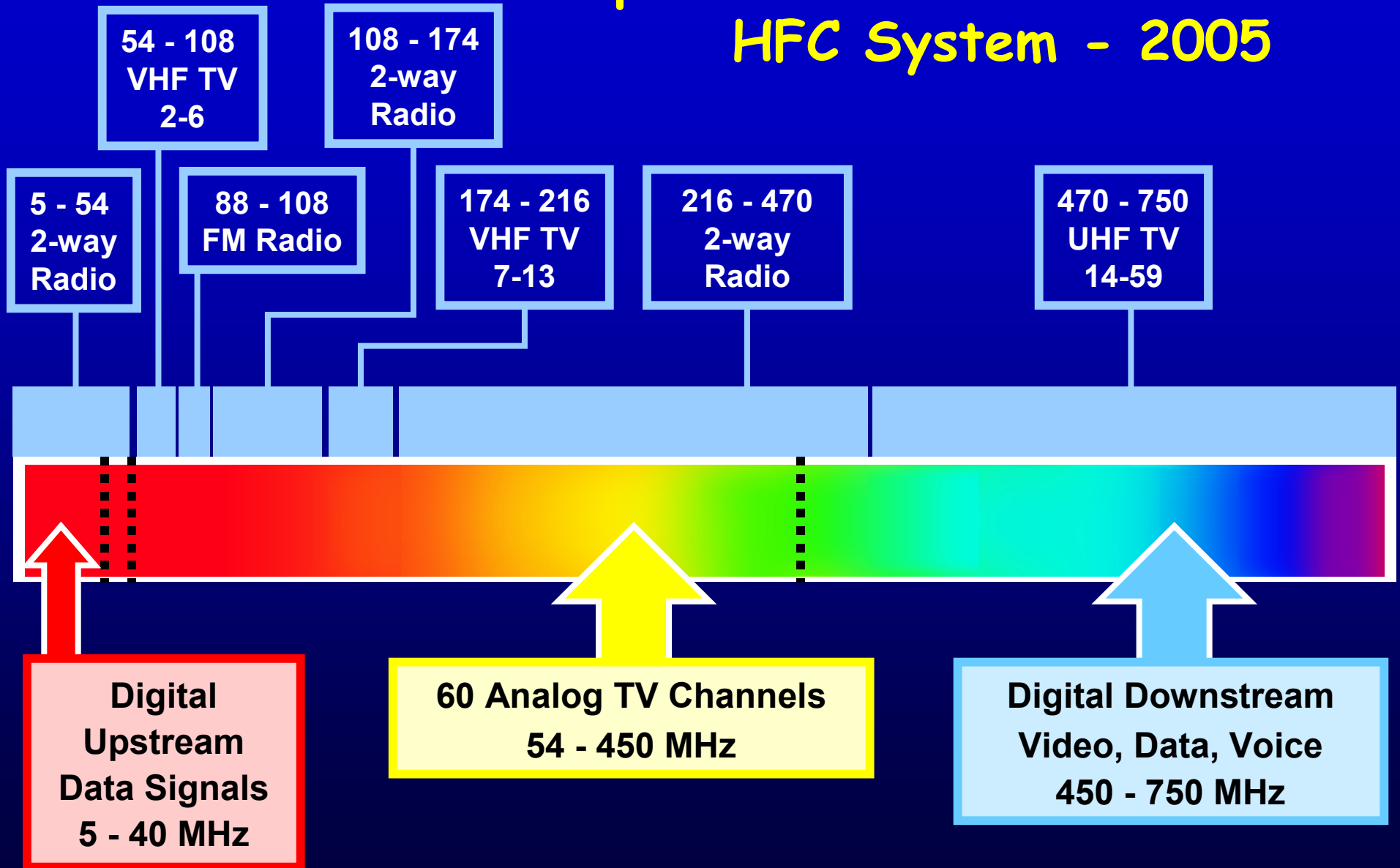

Coaxial Spectrum Allocation HFC System - 2005

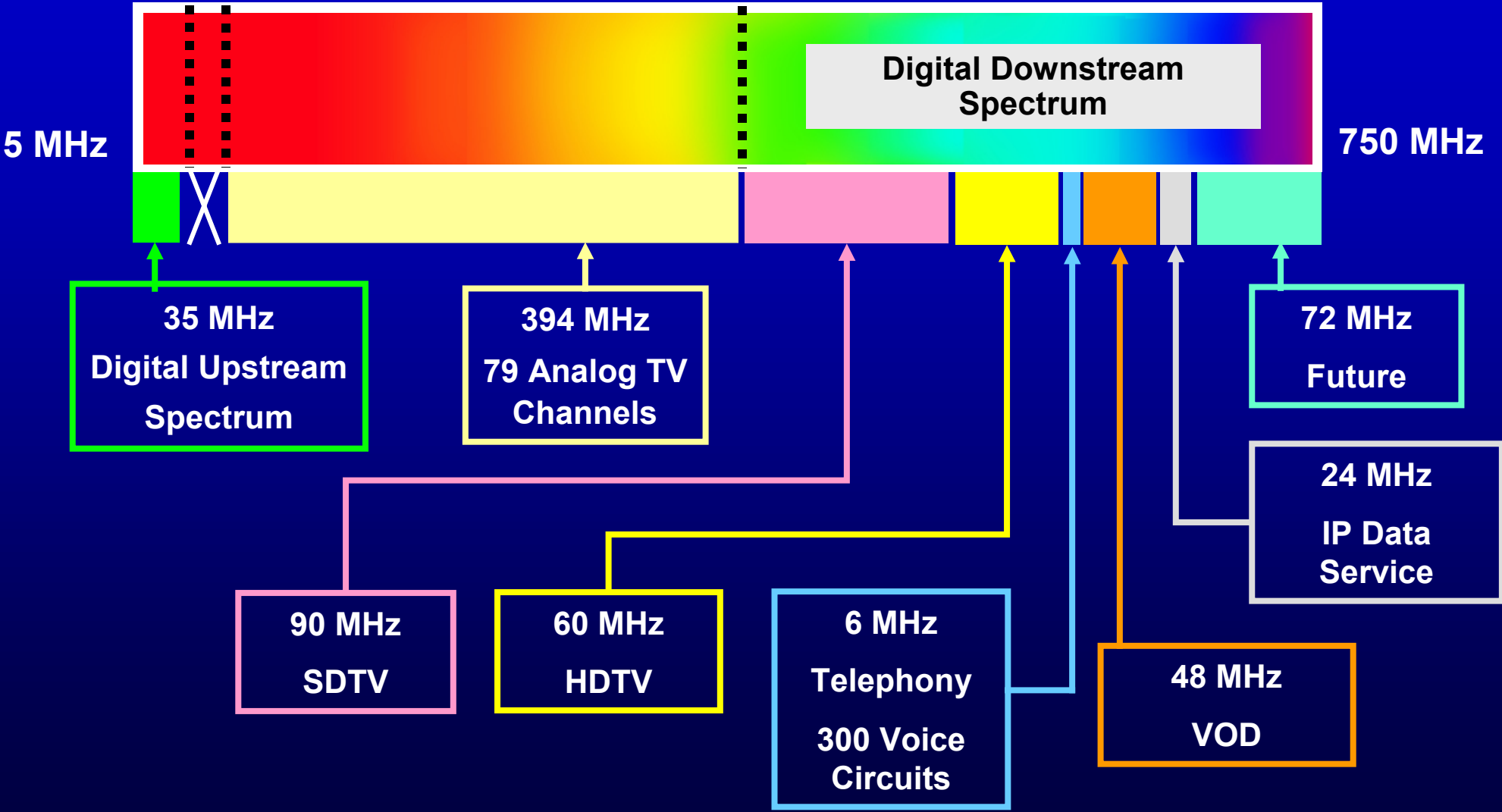

Digital Spectrum - 2005 (One Scenario)

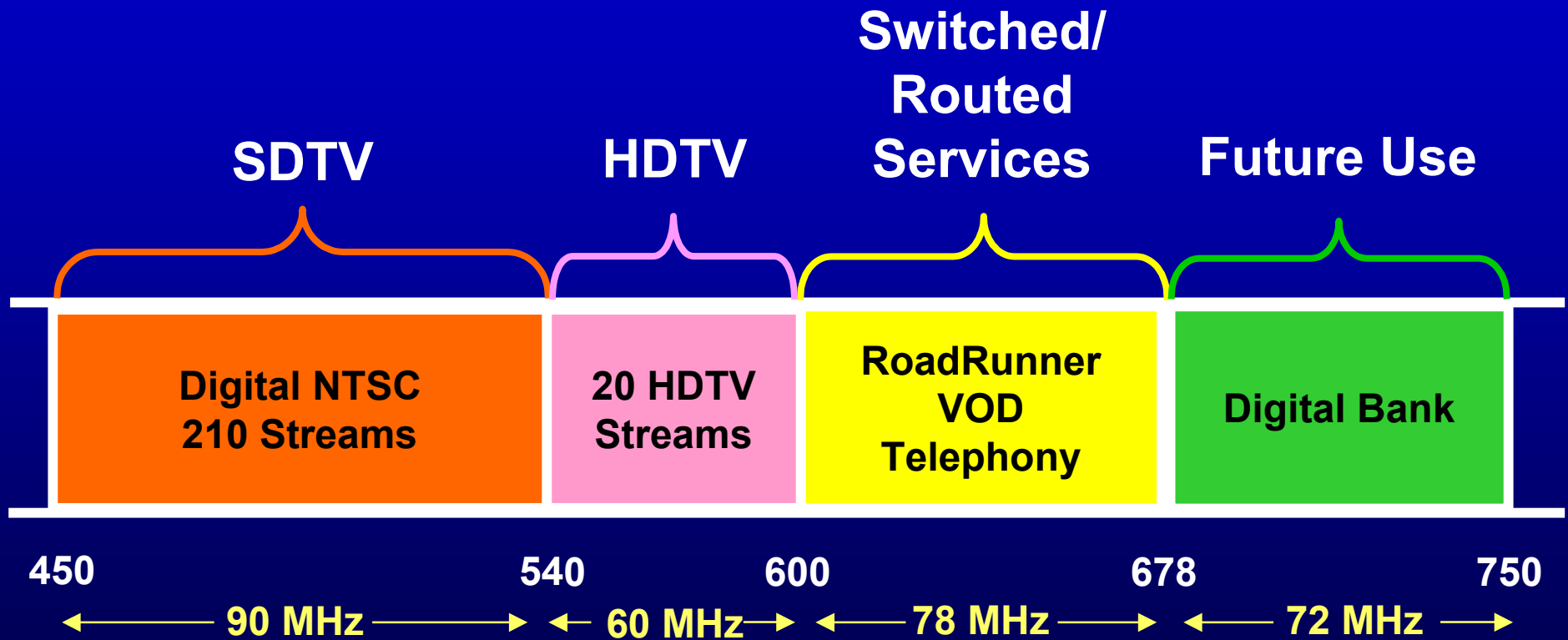

2005 Scenario

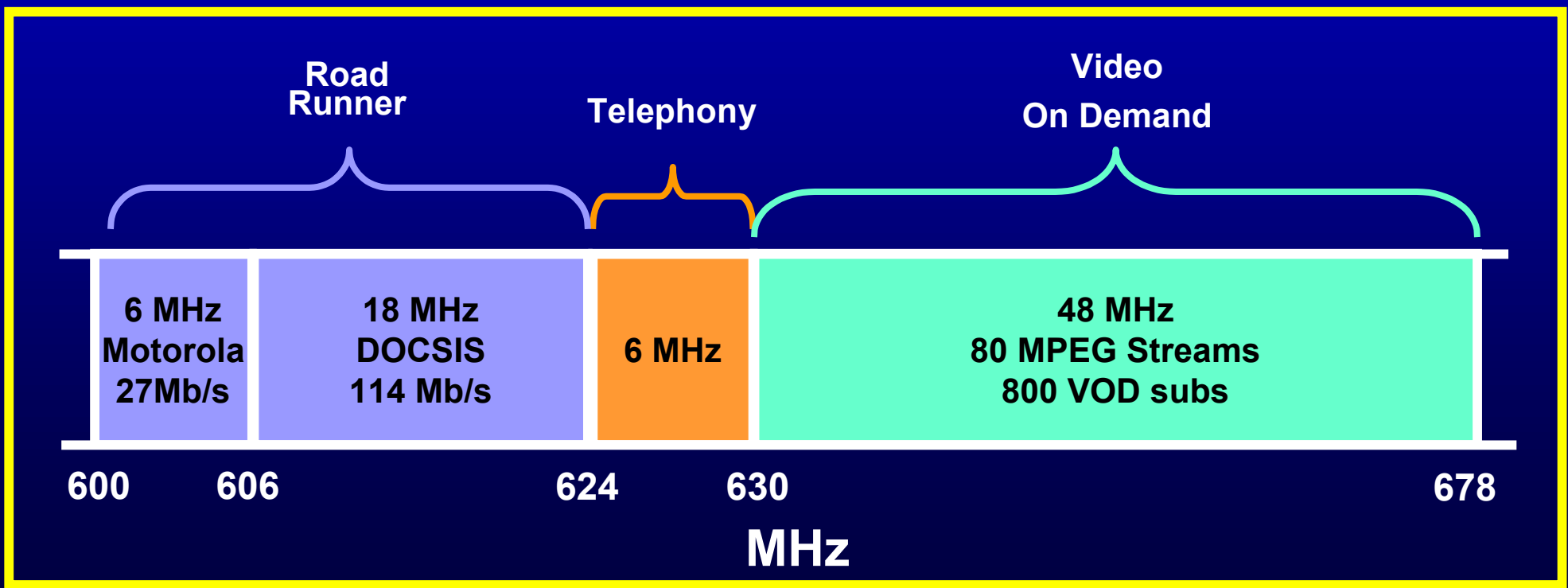
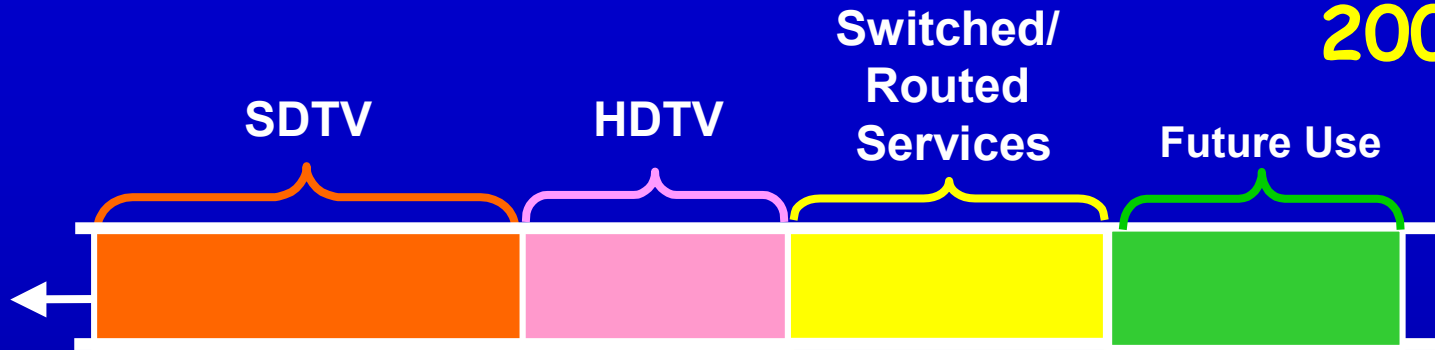

HFC Architecture

Year 2010 Scenario

50 Homes per Node



Multiple-fiber cables

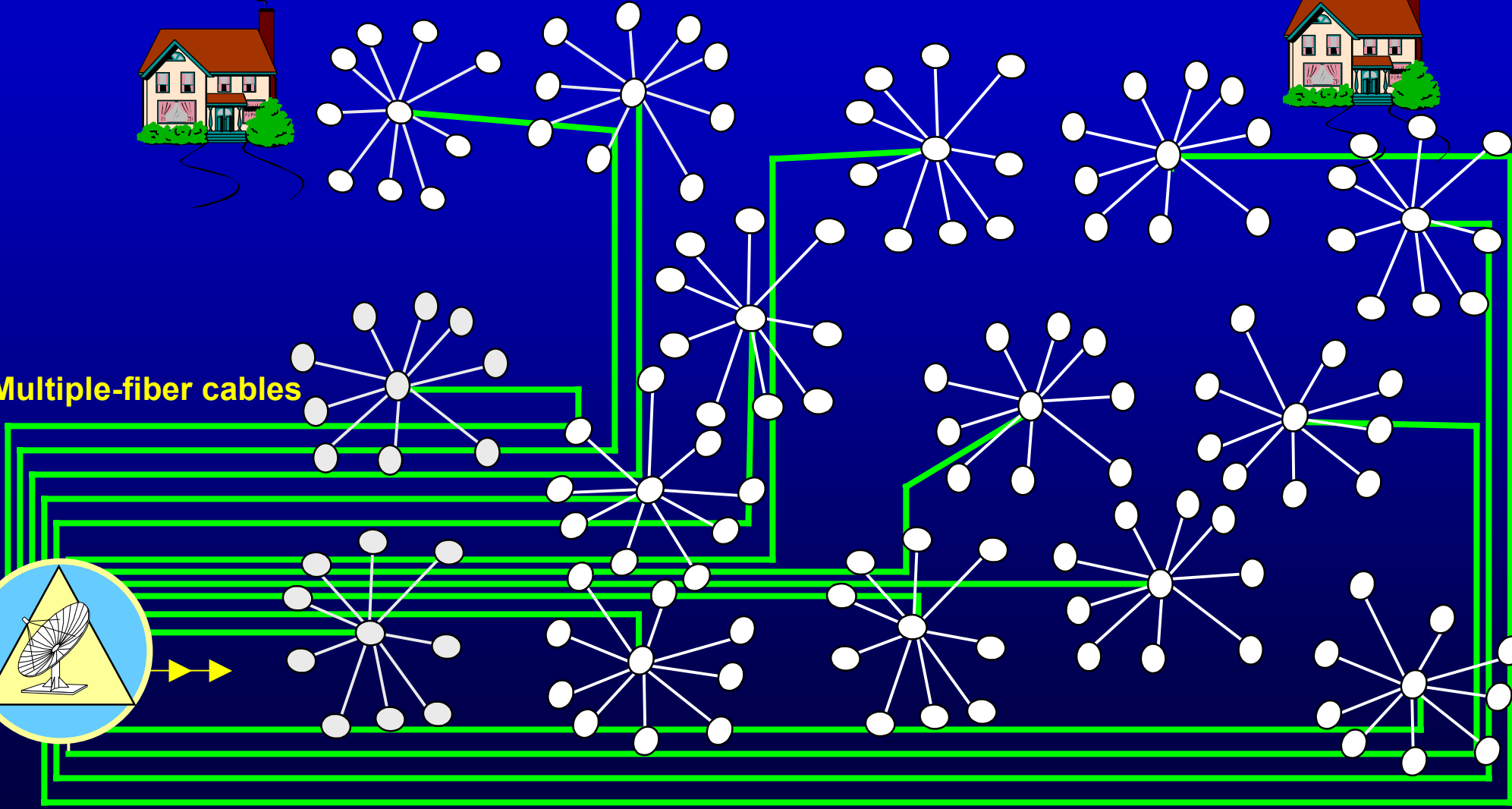
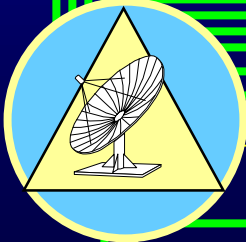

Coaxial Spectrum Allocation HFC System - 2010

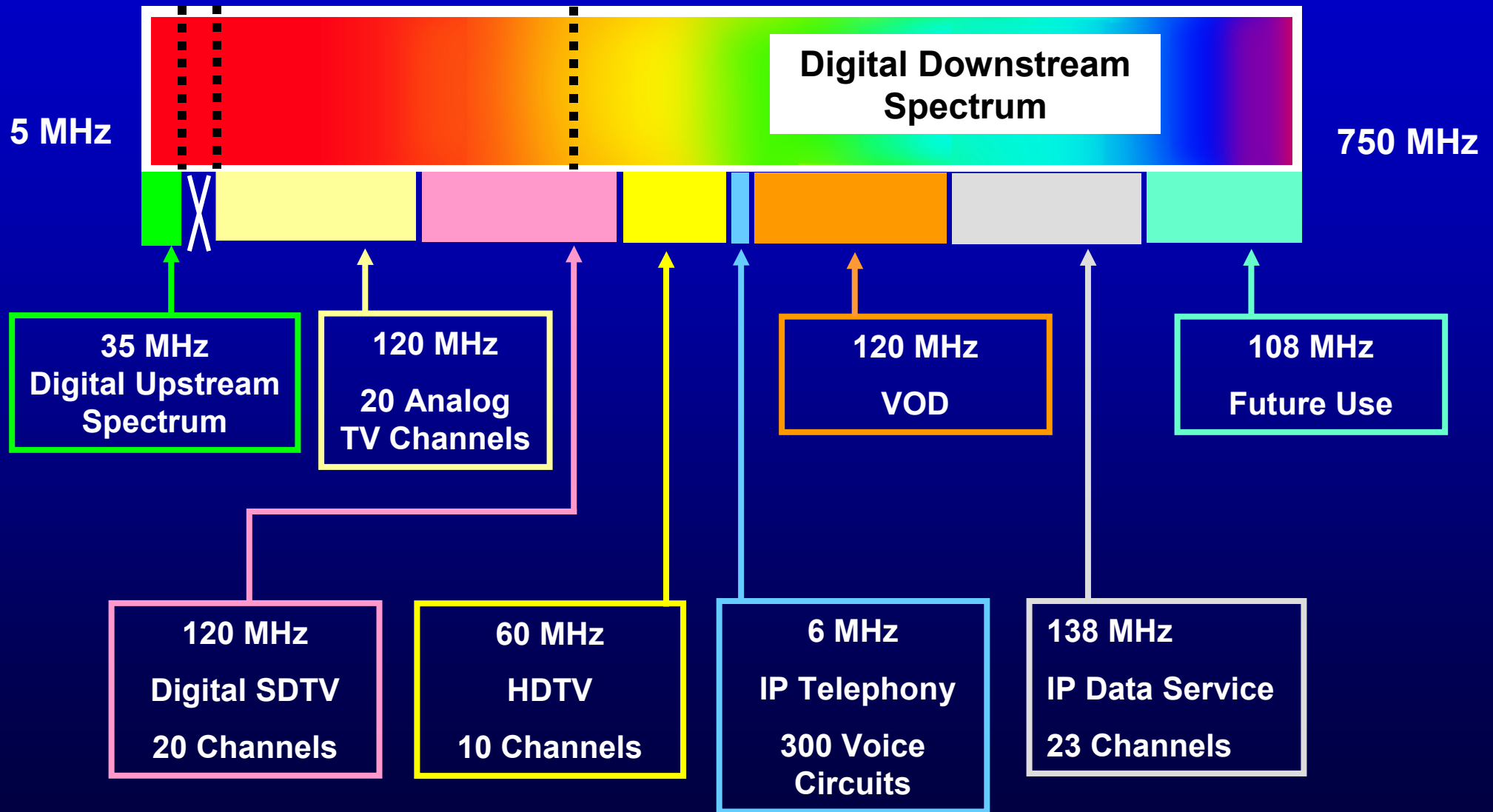

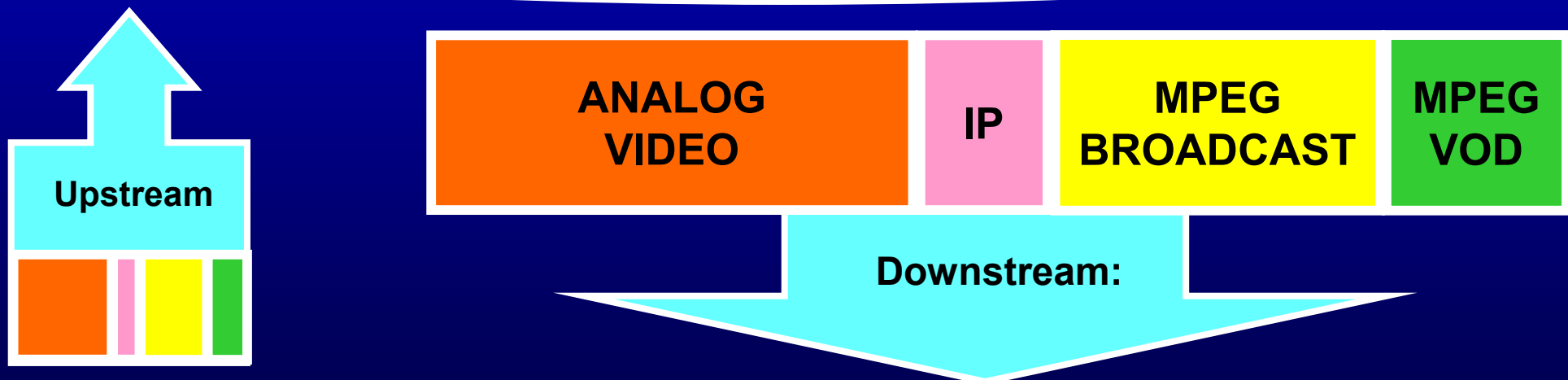
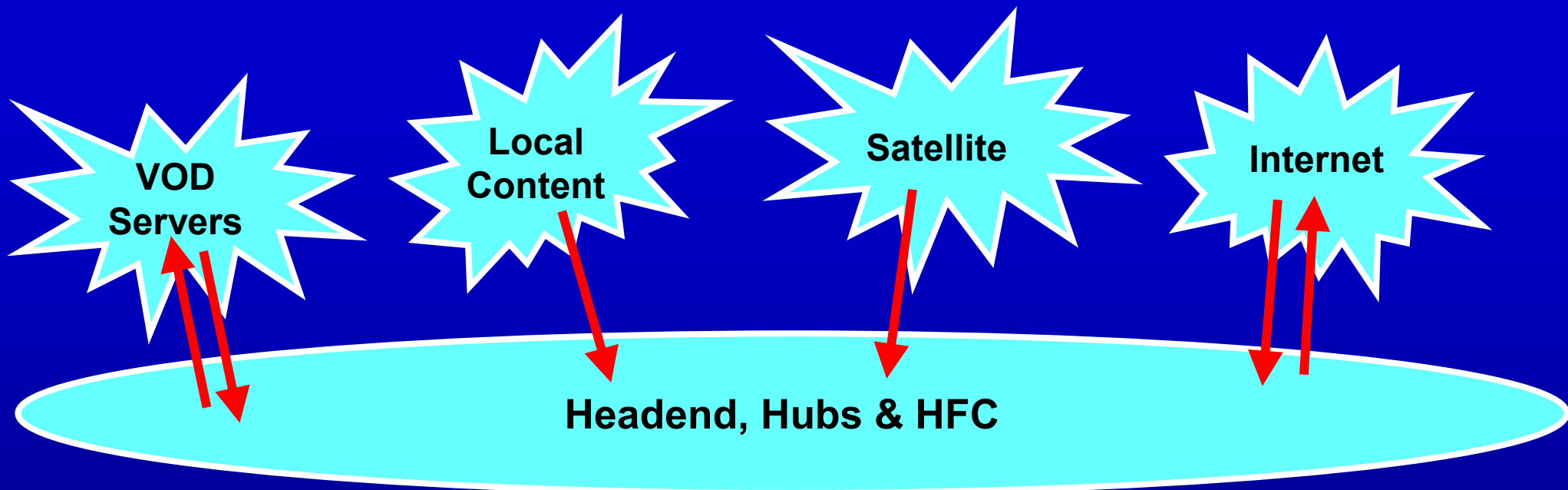

Neighborhood: Either 500, 250, 167, 84, or 42 homes passed

Digital Set-tops: Pegasus

- Born from FSN experiment, circa 1994
- MPEG-2, DVS and DAVIC standards based real-time two-way system
- Deployed in 38 out of 40 divisions
- Current services are:
 - More channels, more channels, more channels
 - On screen digital navigator

Coming Very Soon

- Movies-On-Demand (MOD)
 - Need to resolve title availability
- Subscription VOD
- Enhanced TV
 - ATVEF triggers

Coming Soon

- Personal video recording service
 - Phase I - via set-top boxes with hard disc drives
 - Phase II - via network services
- Higher level integration of:
 - Data and voice services
 - Home networking

Industry Developments

- **OpenCable: Cable's Retail Initiative**
 - **OpenCable Application Platform:
aka middleware**
 - **Separation of Security and Navigation:
POD Module**
 - **Standards based**

OpenCable Architecture

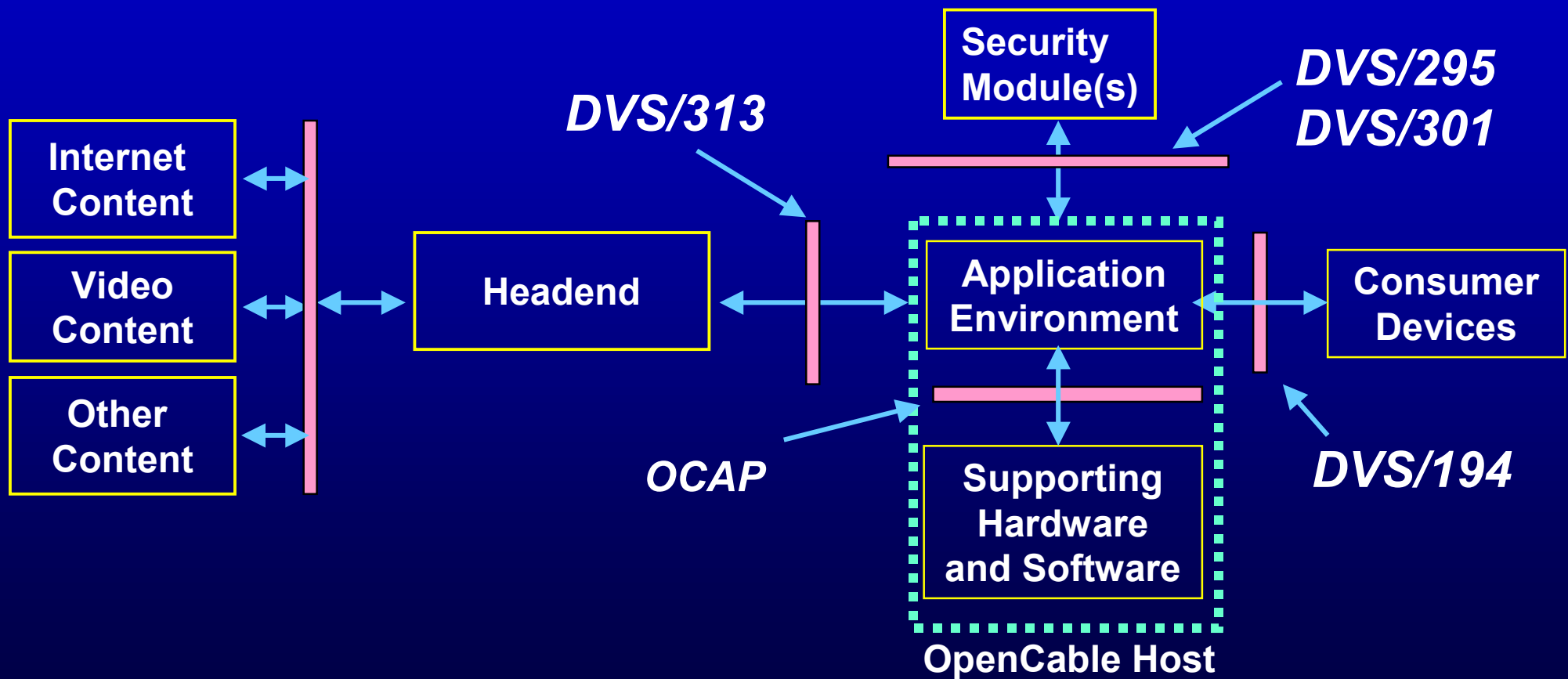

Opportunities

- Cable needs more HD content to differentiate itself from its competitors
 - Spectrum advantages
 - Local advantages
- Cable is a local infrastructure...enhanced services to increase local presence